

CHG BY	CHK BY	RELEASE	REV	REVISIONS	DATE	APPROVED
		---		DESCRIPTION		

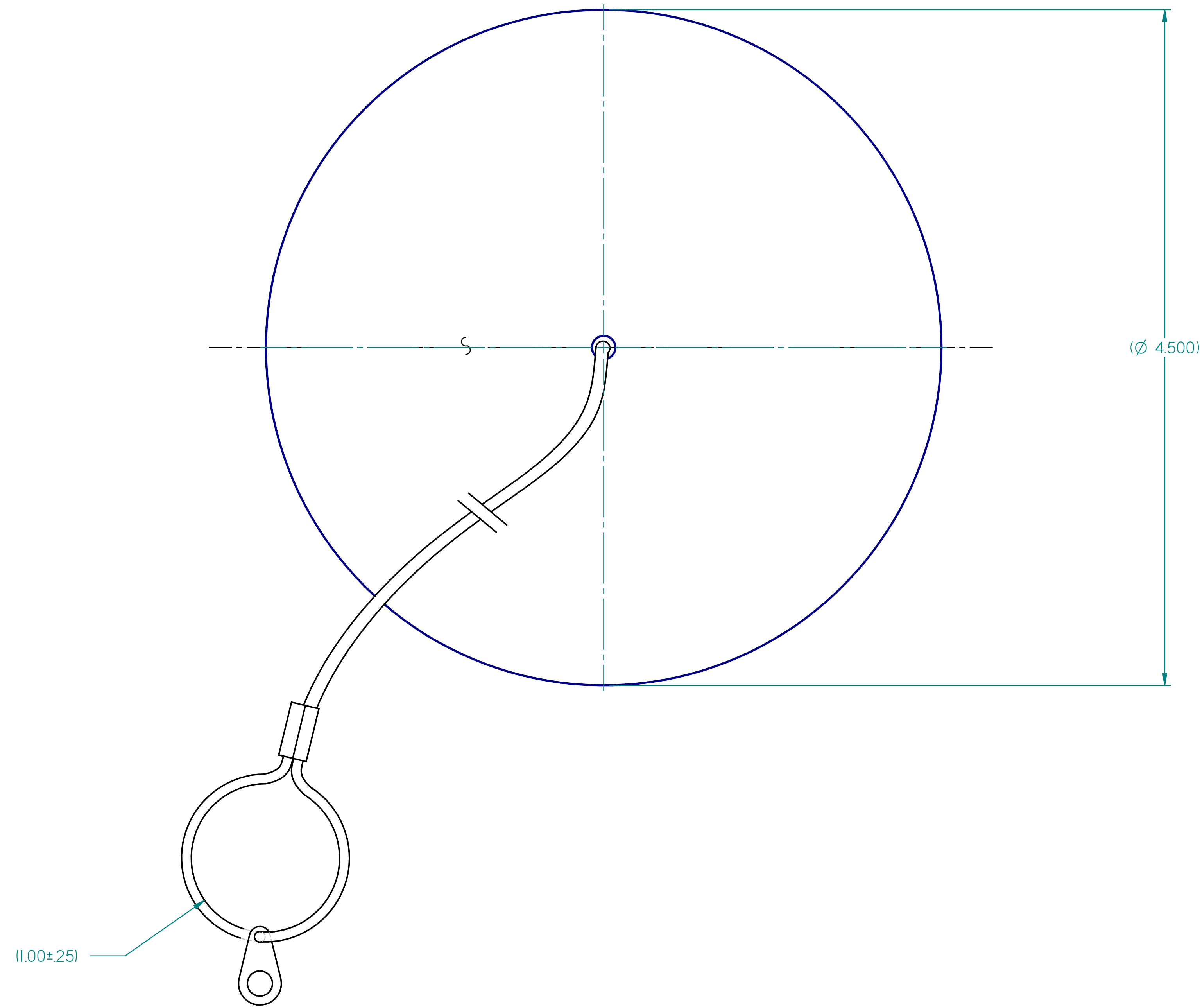
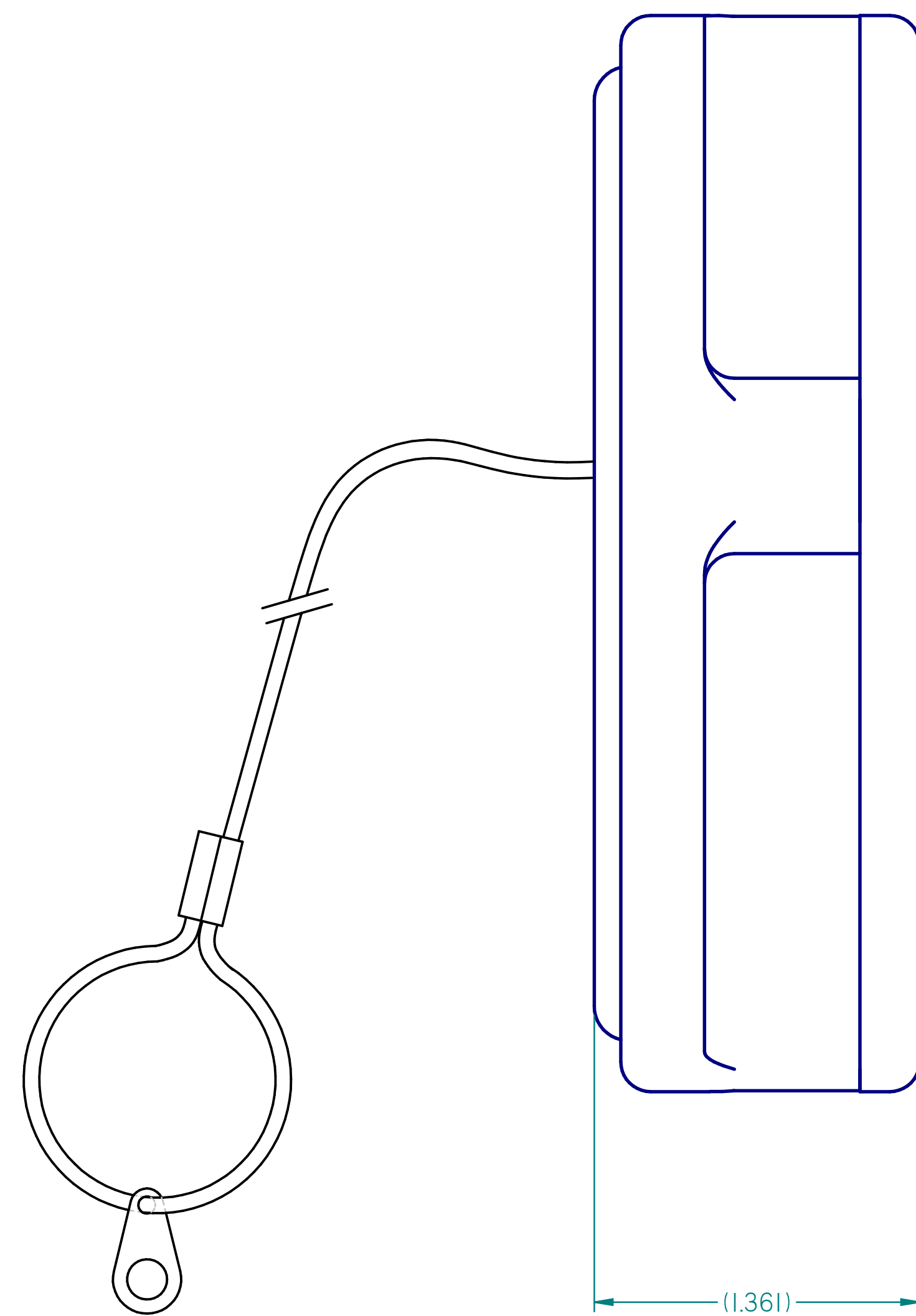

ENVELOPE DRAWING

1. CABLE TOTAL LENGTH IS 12.5 ± .5

NOTES: UNLESS OTHERWISE SPECIFIED

THIS DRAWING IS PROTECTED UNDER COPYRIGHT LAW AND IS THE PROPERTY OF ADEL WIGGINS GROUP, TRANSDIGM INC. DATA CONTAINED HEREIN IS PROPRIETARY TO ADEL WIGGINS GROUP, TRANSDIGM INC. THIS DRAWING AND/OR ANY PART OF THE DATA CONTAINED HEREIN MAY NOT BE COPIED, DUPLICATED OR RELEASED FOR MANUFACTURING OR SALE OF EQUIPMENT OUTSIDE OF ADEL WIGGINS GROUP, TRANSDIGM INC. OR AFFILIATES WITHOUT THE WRITTEN CONSENT OF ADEL WIGGINS GROUP, TRANSDIGM INC.
REV. 12/95

UNLESS OTHERWISE SPECIFIED		DRAWN	T. MASSAR	08-06-07		ADEL WIGGINS GROUP		
DIMENSIONS ARE IN INCHES TOLERANCES ON: ANGLES ± 2° DECIMALS .XX ± .03 DECIMALS .XXX ± .010		CHECK				LOS ANGELES, CA 90022		
INTERPRET SPC FLAGS IN ACCORDANCE WITH ADEL WIGGINS GSP 569		DESIGN			TITLE			
ALL FILLETS, CORNERS AND EDGES R.018/.005		MFG ENGR			CAP ASSEMBLY			
VR325		QUALITY			SIZE	FSCM NO	DWG NO	REV
NEXT ASSY	125 SURFACE FINISH	APPROVED			D	79326	VR304-100A - ENV	NC
	INTERPRET DWG PER MIL-STD-100	CUSTOMER OR GOVT INSP APPROVAL			SCALE	1/1	EST WT	SHEET 1 OF 1